





EFT/ECRPOS-Interface

MPD (Multi Protocol Driver) White Paper

Classification: Public use
Status: Published
Version: 08
Author: heo / vot / dnm (translated by sca)

Date: 24.05.2012
Filename: MPDWhitePaper-V08-en.docx

SIX Payment Services Ltd.
Hardturmstrasse 201
P.O. Box
CH-8021 Zürich

 +41 848 66 11 11
 +41 848 66 11 12

Document History:

This side shows the modification level of this document. Each change has as a consequence a new version.

Version:	Modification:	Author:	Date:
01	Document created in german	heo	07.09.2003
01e	Document translated in english	sca	01.12.2003
02	small revision	vot	16.03.2004
03	updated	vot	06.09.2005
04	updated	vot / dnm	28.03.2007
05	Extended with CXI for cCredit and small adjustments	vot	30.06.2008
06	Updated Company name	dnm	02.11.2009
07	updated	vot / dnm	07.07.2010
08	Updated Company name	dnm	24.05.2012

Content

1	Introduction	4
2	Concept	5
2.1	MPD Solution	5
2.2	Conventional ECR-Interface Solution	5
3	Characteristics / Advantages	6
3.1	Operating System.....	6
3.2	Programming Languages	6
3.3	EFTPOS Protocols	6
3.4	ECRPOS Protocols	6
3.5	Logfunction	6
3.6	Communication protocol.....	7
3.7	Advantages.....	7
4	technical integration	8
4.1	Visual Basic Code Example	8
5	MPD Products	9
5.1	MPD compatible EFTPOS Terminals (ISDN, X.25)	9
5.2	MPD compatible EFTPOS Terminals (ISDN and TCP/IP)	9
5.3	SDK	9
6	Requirements for a successful implementation of the MPD	10
6.1	Technical	10
6.2	Administration.....	10
7	Services	10
8	Contact	10

1 Introduction

The MPD is a multifunctional cash register interface driver for all EFTPOS terminals from SIX Payment Services AG. The MPD is able to provide all of the major communication protocols to the cash register over a simple homogenous interface.

The cash registry application doesn't have to bother about the ECR-Protocol. Instead it can process the payment function immediately through the simple generic interface (API). If an EFTPOS terminal is exchanged, the driver automatically detects the communication protocol and provides the payment function to the ECR-Application over the same interface.

The cash register manufacturer is able to install the MPD quickly and easily into his application. The driver controls all the relevant communication states and provides an economical and secure process of the payment. Since the MPD is already homologated and also optimally coordinated with the products of the SIX Payment Services AG, costs for the certification of the cash register are effectively reduced.

2 Concept

2.1 MPD Solution

The MPD offers a simple integration into all ECRPOS-Applications as well as system environments. Only one interface is needed to be able to communicate with all of the payment functions. The MPD is simple to configure and accomplishes payments reliably.

Since the MPD is already homologated with most of the EFTPOS terminals costs for the certification of the ECRPOS systems are negligible.

Furthermore the MPD has the function of having transactions being processed through the TCP/IP protocol of the cash registry net * (Configuration: Communication "ECR" and MPD interface "MPDoverRS232").

The MPD makes it possible, (with davinci PINPAD and xenta PINPAD) only with a LAN connection (without a RS232 connection), to provide the functions of the EFTPOS terminal to the ECRPOS system (configuration: Communication "LAN" and MPD interface "MPDoverIP").

The following graphic shows the MPD solution with the integrated TCP/IP interface.

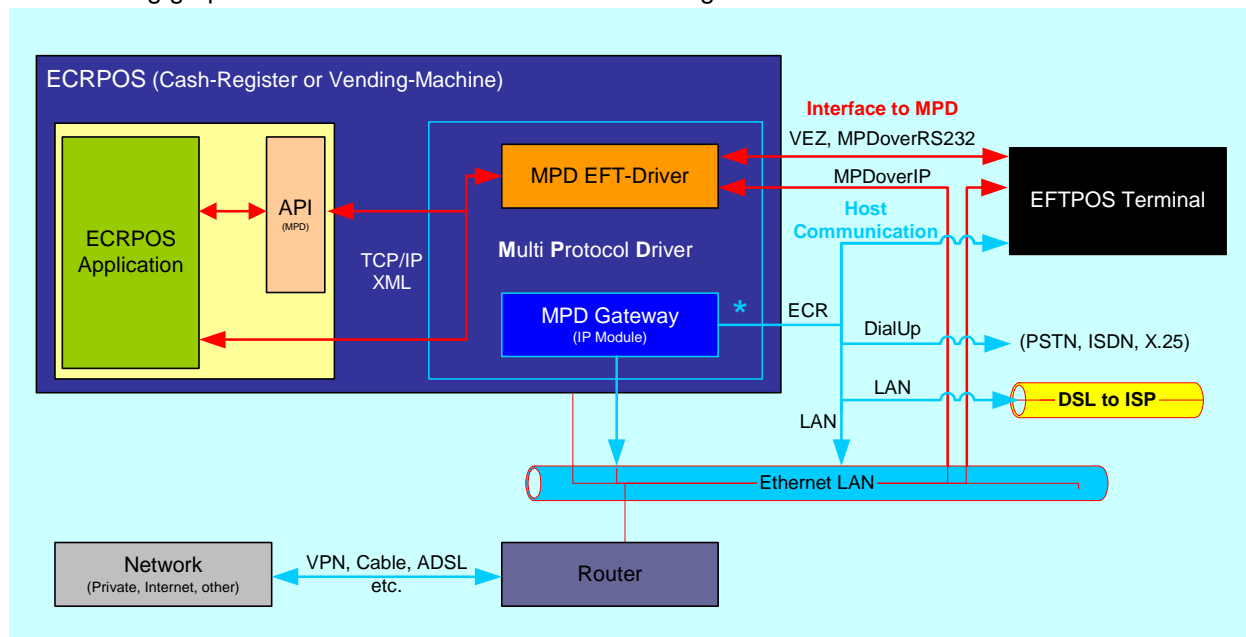

2.2 Conventional ECR-Interface Solution

The conventional solution of connecting the EFTPOS terminal with the cash register involved the process of making one or more complex interfaces. Finally, the complete System (ECRPOS and EFTPOS terminal) had to be homologated. Due to the fact, that the MPD is already homologated this time consuming and costly step doesn't have to be done again.

3 Characteristics / Advantages

3.1 Operating System

The MPD is delivered as a 32 and 64-bit application and runs under the following systems:

- Windows NT, 2000, XP, Vista und 7
- Windows CE
- Linux
- MAC OS X

If your operating system is not in the list please contact us, so that we can compile a solution together.

3.2 Programming Languages

The MPD-API will accept the following programming languages:

- .net
- Java
- Visual Basic/COM
- Visual Foxpro
- VB-Script
- Perl
- C#
- C++
- Delphi
- Xcode
- other

3.3 EFTPOS Protocols

The following EFTPOS Protocols are supported:

- VEZ 5.1
- KESS 1.0
- VEZep2
- VEZplus
- CXI

3.4 ECRPOS Protocols

The following XML cash register protocols are supported by the MPD:

- MPD
- O.P.I.
- CXI

3.5 Logfunction

The MPD constantly records and stores these in daily provided log files. Sensitive data are masked.

3.6 Communication protocol

On the EFTPOS terminals the normal communication protocols (ISDN, PSTN, X.25 and LAN) are supported. On top of this the MPD also allows the transaction processing through the cash register over TCP/IP. The following communication protocols are available.

- PSTN (X.28)
- ISDN-B
- X.25
- TCP/IP
- TCP/IP over MPD Gateway

3.7 Advantages

Software houses and cash register manufacturers/distributors can profit from the following advantages:

- self explanatory API
- extensive MDP implementation guide and development help
- the modular architecture and the possibilities of the function allows the acceptance of different payment flows
- independent of the operating system
- supports many different development environment
- different references
- low cost homologation
- quick time to market
- secure transaction flow
- migration is compatible
- ep2 is completely supported

4 technical integration

The following example shows how easily the MPD is integrated into a cash register surrounding.

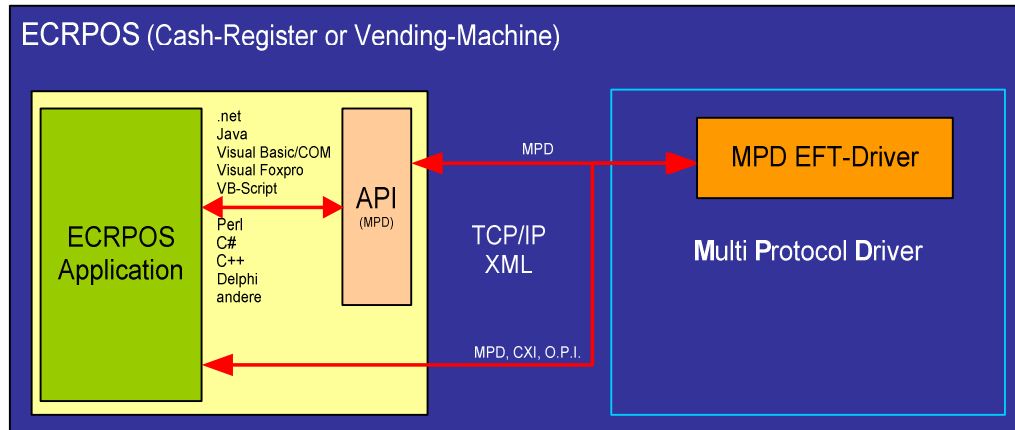

4.1 Visual Basic Code Example

The following shows how a payment flow runs over the API

The runtime library can be accessed from the Windows Scripting Host using synchronous method calls. To create a new EFTDriver object

```
Set eft = CreateObject("eftoa.EFTDriver")
```

is called. Once this is done, we can configure and open the EFT device by calling

```
eft.Async = False
eft.Currency = "CHF"
eft.Open
```

A runtime error will be generated, when the function fails. A new transaction can be started now:

```
eft.Transaction "debit", 100
```

If no error occurs, the device is ready to

```
eft.Commit True
```

and the transaction has completed. After that we may

```
eft.Close
```

finish the shift. Other methods and properties work as well from WSH.

5 MPD Products

With the MPD all of the normal EFTPOS terminals can be served. The following products are available:

5.1 MPD compatible EFTPOS Terminals (ISDN, X.25)

Product	Description
card-x S3 *	The card-x S3 is the most popular level3 EFTPOS terminal and market leader in Switzerland. It supports VEZ 5.1 ECRPOS-Interface as well as KESS 1.0.
3C vegas *	The 3C vegas features a big graphical display as well as a motorized card reader. It supports VEZ 5.1 ECRPOS-Interface.
card-box *	The card-box is especial designed for vending machines. It supports VEZ 5.1 ECRPOS-Interface.
EPSYS Smash *	Our product with swipe type card reader. VEZ 5.1
Card-X 2000 / 2010 *	The older very popular terminal population. VEZ 5.1

* System availability secured until the end of 2010.

5.2 MPD compatible EFTPOS Terminals (ISDN and TCP/IP)

Product	Description
smash PINPAD *	The first product according to ep2, with plugging reader for chip and pull-through reader for magnetic stripes. VEZ as well as ep2.
xenta PINPAD *	The current product with plugging reader for chip and pull-through reader for magnetic stripes. VEZ as well as ep2.
xentissimo PINPAD *	The product with plugging reader for chip and pull-through reader for magnetic stripes works independent over a wireless network location. VEZ as well as ep2.
davinci PINPAD * & davinci CHECKOUT *	The product with motorized hybrid-reader for the served point of sale. VEZ as well as ep2.
davinci VENDING **	The product with motorized hybrid-reader for the employment in the vending machine. VEZ as well as ep2.
cCredit *	cCredit the transaction platform for a safe and performance transmission of card data.

* served point of sales

** unattended point of sales

5.3 SDK

A SDK (Software Development Kit) is available. It includes a reference-implementation, a complete help-file, tools, an implementation guide and a testing script to check the integration.

6 Requirements for a successful implementation of the MPD

6.1 Technical

- 32 and 64-bit operating system
- programming knowledge and good know-how about cash register application
- EFTPOS terminal simulator for test's is available.

6.2 Administration

- NDA in case of source code handover
- Final conjoint approval with SIX Quality-Assurance test

7 Services

- Free sales-consulting
- Development support per e-mail or telephone
- Development support outside SIX will be charged separately

8 Contact

For further information please contact our sales representative.

SIX Payment Services Ltd.
Hardturmstrasse 201
P.O. Box
CH-8021 Zürich

 +41 848 66 11 11

 +41 848 66 11 12